

Wi-Fi Temperature Sensor



Technical Overview

General Description

The OEM Wi-Fi Temperature Sensor uses a thermistor to accurately measure temperatures from -40°C to 85°C . Perfect for slower changing temperatures and critical applications such as facilities or room monitoring. An integrated 802.11 b/g radio allows the sensor to work with any existing Wi-Fi network. OEM Wi-Fi sensors can be easily programmed with your Wi-Fi network's WEP or WPA(2) security via the free WiFi Sensor Setup Utility (PC application) and a USB programming cable (available in the [Monnit web store](#)). User defined transmission intervals (heartbeats) and sensor threshold settings ensure that sensor data is received when needed, based on the application.

Features

- Accurate to $\pm 1^{\circ}\text{C}$ ($\pm 1.8^{\circ}\text{F}$).
- Increased accuracy by user calibration to $\pm 0.25^{\circ}\text{C}$ ($\pm 0.45^{\circ}\text{F}$).
- Logs data if Wi-Fi network is disrupted.
- Free iMonnit basic online wireless sensor monitoring and notification system to configure sensors, view data and set alerts via SMS text and email.

(iMonnit online software is available as an OEM private / white label platform.)

Principle of Operation

The OEM Wi-Fi Temperature Sensor outputs the ambient temperature in degrees Fahrenheit or Celsius. It is programmed to sleep for a user-specified time interval (heartbeat) and then wakeup, send power to the NTC Thermistor, wait for the reading to stabilize, calculate the temperature and transmit the information to the wireless gateway. To stay within the abilities of the processor, the temperature is computed from a data table provided by the manufacturer. To reduce error, a variable resistor configuration is implemented over specified temperature ranges.

OEM Wi-Fi Sensor Electronics Specifications

- Power: 2 replaceable 1.5V "AA" batteries (included)
- Communication: 802.11 b/g
(2.412 - 2.484 GHz)
- Wi-Fi Security: Open, WEP, WPA, WPA2
- Dimensions: 3.02" x 2.1" x 1.27"
- Transmission Range: Up to 250 ft. *
- Battery Life: Up to 5 years.**

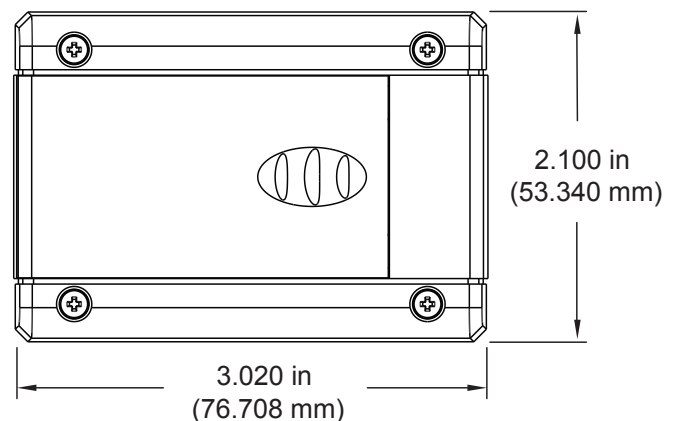

* Actual range may vary depending on environment.
** Battery life is affected by sensor type, Wi-Fi security type, distance from Wi-Fi router, reporting frequency and other variables.

Height: 1.270 in (32.258 mm)



Applications

- Ambient Temperature Monitoring
- Environmental Monitoring
- Smart Machines & Smart Structures
- HVAC Operation & Testing
- Data Center Monitoring

Technical Specifications	
Networking Standards	IEEE 802.11 b/g
Frequency Band	2.412 - 2.484 GHz
Wi-Fi Security Standards	Open, WEP, WPA, WPA2
Wi-Fi Security Programming	Via PC software using USB cable. (Can be changed through online software.)
Network Settings	Auto DHCP/DNS or Static
Data Logging	Standard - On Wi-Fi disruption, unit will log the first 50 readings and transmit when Wi-Fi connection is re-established. Premiere - Unit can record up to 50,000 readings and transmit when Wi-Fi is available.
Power consumption	4uA sleep, 35mA active RX, 180mA TX (at +12dBm)
Battery Life	Up to 5 years depending on sensor type, Wi-Fi security, distance from Wi-Fi router, reporting frequency and other variables. (Testing surpassed 90,000 transmissions until battery depletion.)
Wi-Fi Data Rate	Auto configures to best rate for maximum range.
Wireless Range	Up to 250 ft. device range (typical to standard Wi-Fi devices).
Electronics Operating Temperature	Using Alkaline Batteries: -18°C to +55°C (0°F to +130°F) Using Lithium Batteries: -40°C to +85°C (-40°F to +185°F)
LED Light	Status / activity
Certifications	   Industry Canada FCC ID: T9J-RN171. IC: RSS-210 low-power communication device. CE ID: 0681.

Thermistor Specifications	
Thermistor Operating Range	-40°C to 125°C
Accuracy @ 25°C	+/- 1%
Resistance @ 25°C	10K ± 1%
B-Constant (25°C – 50°C)	3380 ± 1%
Permissive Operating Current @ 25°C	0.38 mA
Rated Electric Power @ 25°C	15 mW
Dissipation Constant @ 25°C	1.5mW/°C
Time Constant @ 25°C	7 sec

- * Hardware can not withstand negative voltage. Please take care when connecting a power device.
- ** At temperatures above 100°C, it is possible for the board circuitry to lose programmed memory.

For more product information, to get a quote, or to place an order, please contact our sales department at 801-561-5555. Visit us on the web at www.oemsensors.com.

OEMSensors.com | 7304 South Cottonwood, Suite #204 | Midvale, Utah 84047 | 801-561-5555 | www.oemsensors.com