



Wi-Fi Dry Contact Sensor

Technical Overview

General Description

The OEM Wi-Fi Dry Contact Sensor can be used to detect contact between two wired contact points that can be used with an external mechanical switch or a contact plate. An integrated 802.11 b/g radio allows the sensor to work with any existing Wi-Fi network. OEM Wi-Fi sensors can be easily programmed with your Wi-Fi network's WEP or WPA(2) security via the free Wi-Fi Setup Utility (PC application) and a USB programming cable (available in the [Monnit web store](#)). User defined transmission intervals (heartbeats) and sensor threshold settings ensure that sensor data is received when needed, based on the application.

Features

- Senses immediate contact between wires.
- Can also sense when contact is broken.
- Product comes with standard 36 inch lead.
- Logs data if Wi-Fi network is disrupted.
- Free iMonnit basic online wireless sensor monitoring and notification system to configure sensors, view data and set alerts via SMS text and email.

(iMonnit online software is available as an OEM private / white label platform.)

Principle of Operation

The OEM Wi-Fi Dry Contact Sensor detects when their is contact between the two wired end points. It can easily be integrated into existing switches or contact plates. When the sensor detects contact between the two end points, it will immediately turn on the RF radio and transmit the data to the wireless gateway and iMonnit Online Sensor Monitoring and Notification System, allowing the user to immediately receive an SMS text or email alert. The sensor can be configured to detect both closed and open loops alerting if contact is made or broken.

OEM Wi-Fi Sensor Electronics Specifications

- Power: 2 replaceable 1.5V "AA" batteries (included)
- Communication: 802.11 b/g
(2.412 - 2.484 GHz)
- Wi-Fi Security: Open, WEP, WPA, WPA2
- Dimensions: 3.02" x 2.1" x 1.27"
- Transmission Range: Up to 250 ft. *
- Battery Life: Up to 5 years.**

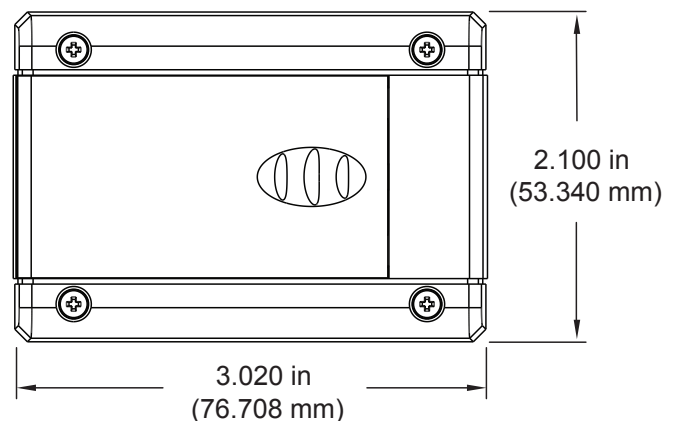

* Actual range may vary depending on environment.
** Battery life is affected by sensor type, Wi-Fi security type, distance from Wi-Fi router, reporting frequency and other variables.

Height: 1.270 in (32.258 mm)



Applications

- Warehouse door monitoring.
- Freezer / cooler door monitoring.
- Forklift seat switches.
- Button or switch integration.
- Production line tracking.

Technical Specifications	
Networking Standards	IEEE 802.11 b/g
Frequency Band	2.412 - 2.484 GHz
Wi-Fi Security Standards	Open, WEP, WPA, WPA2
Wi-Fi Security Programming	Via PC software using USB cable. (Can be changed through online software.)
Network Settings	Auto DHCP/DNS or Static
Data Logging	Standard - On Wi-Fi disruption, unit will log the first 50 readings and transmit when Wi-Fi connection is re-established. Premiere - Unit can record up to 50,000 readings and transmit when Wi-Fi is available.
Power consumption	4uA sleep, 35mA active RX, 180mA TX (at +12dBm)
Battery Life	Up to 5 years depending on sensor type, Wi-Fi security, distance from Wi-Fi router, reporting frequency and other variables. (Testing surpassed 90,000 transmissions until battery depletion.)
Wi-Fi Data Rate	Auto configures to best rate for maximum range.
Wireless Range	Up to 250 ft. device range (typical to standard Wi-Fi devices).
Electronics Operating Temperature	Using Alkaline Batteries: -18°C to +55°C (0°F to +130°F) Using Lithium Batteries: -40°C to +85°C (-40°F to +185°F)
LED Light	Status / activity
Lead Wire Length	3 ft. (36 in.)
Certifications	   FCC ID: T9J-RN171. IC: RSS-210 low-power communication device. CE ID: 0681.

* Hardware can not withstand negative voltage. Please take care when connecting a power device.

** At temperatures above 100°C, it is possible for the board circuitry to lose programmed memory.

For more product information, to get a quote, or to place an order, please contact our sales department at 801-561-5555. Visit us on the web at www.oemsensors.com.

OEMSensors.com | 7304 South Cottonwood, Suite #204 | Midvale, Utah 84047 | 801-561-5555 | www.oemsensors.com