

Wi-Fi Open / Closed Sensor

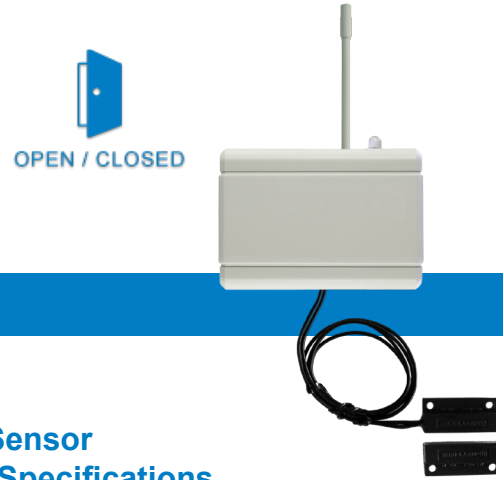

Technical Overview

General Description

The OEM Wi-Fi Open/Closed Sensor provides information on the status of doors, windows, cabinets, etc. Know if a building or specific area is being accessed when it should not be, or if a door or window has been left open. An integrated 802.11 b/g radio allows the sensor to work with any existing Wi-Fi network. OEM Wi-Fi sensors can be easily programmed with your Wi-Fi network's WEP or WPA(2) security via the free Wi-Fi Setup Utility (PC application) and a USB programming cable (available in the [Monnit web store](#)). User defined transmission intervals (heartbeats) and sensor threshold settings ensure that sensor data is received when needed, based on the application.

Features

- Detects when a door or window is accessed.
- Magnet is included.
- Logs data if Wi-Fi network is disrupted.
- Free iMonnit basic online wireless sensor monitoring and notification system to configure sensors, view data and set alerts via SMS text and email.

(iMonnit online software is available as an OEM private / white label platform.)

Principle of Operation

The OEM Wi-Fi Open/Closed Sensor uses a wired reed switch to detect the presence or removal of a magnetic source. When the sensor detects that the magnet is removed or returned it sends the information to the iMonnit Online Sensor Monitoring and Notification System. The data is stored in the online system and can be reviewed and exported as a data sheet or graph. Notifications can be set up through the online system to alert the user when a magnetic source is present or not with the ability to only notify within time of day parameters.

OEM Wi-Fi Sensor Electronics Specifications

- Power: 2 replaceable 1.5V "AA" batteries (included)
- Communication: 802.11 b/g
(2.412 - 2.484 GHz)
- Wi-Fi Security: Open, WEP, WPA, WPA2
- Dimensions: 3.02" x 2.1" x 1.27"
- Transmission Range: Up to 250 ft. *
- Battery Life: Up to 5 years.**

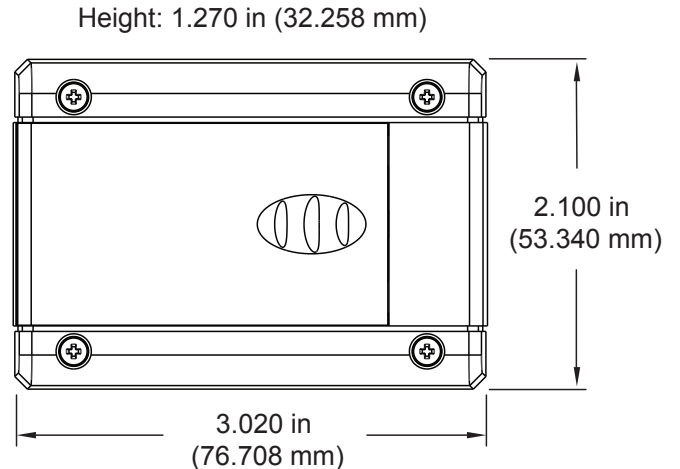

* Actual range may vary depending on environment.
** Battery life is affected by sensor type, Wi-Fi security type, distance from Wi-Fi router, reporting frequency and other variables.



Applications

- Doors and windows.
- Cabinets and lockers.
- IT server closets.
- Freezer and cooler doors.

Technical Specifications

Networking Standards	IEEE 802.11 b/g
Frequency Band	2.412 - 2.484 GHz
Wi-Fi Security Standards	Open, WEP, WPA, WPA2
Wi-Fi Security Programming	Via PC software using USB cable. (Can be changed through online software.)
Network Settings	Auto DHCP/DNS or Static
Data Logging	Standard - On Wi-Fi disruption, unit will log the first 50 readings and transmit when Wi-Fi connection is re-established. Premiere - Unit can record up to 50,000 readings and transmit when Wi-Fi is available.
Power consumption	4uA sleep, 35mA active RX, 180mA TX (at +12dBm)
Battery Life	Up to 5 years depending on sensor type, Wi-Fi security, distance from Wi-Fi router, reporting frequency and other variables. (Testing surpassed 90,000 transmissions until battery depletion.)
Wi-Fi Data Rate	Auto configures to best rate for maximum range.
Wireless Range	Up to 250 ft. device range (typical to standard Wi-Fi devices).
Electronics Operating Temperature	Using Alkaline Batteries: -18°C to +55°C (0°F to +130°F) Using Lithium Batteries: -40°C to +85°C (-40°F to +185°F)
LED Light	Status / activity
Certifications	   Industry Canada FCC ID: T9J-RN171. IC: RSS-210 low-power communication device. CE ID: 0681.

Magnetic Switch Specifications

Operation Time	0.5 ms (max)
Release Time	0.1 ms (max)
Shock	11ms ½ sine wave / 100 g (max)
Vibration	50 - 2000 Hertz / 30 g (max)
Resonant Frequency	8500 Hz (typ)
Pull-In Range	10 - 25 Ampere Turns
Rating Sensitivity	15 Ampere Turns

* Hardware can not withstand negative voltage. Please take care when connecting a power device.

** At temperatures above 100°C, it is possible for the board circuitry to lose programmed memory.

For more product information, to get a quote, or to place an order, please contact our sales department at 801-561-5555. Visit us on the web at www.oemsensors.com.

OEMSensors.com | 7304 South Cottonwood, Suite #204 | Midvale, Utah 84047 | 801-561-5555 | www.oemsensors.com