

## Wi-Fi High Temperature Sensor



### Technical Overview

#### General Description

The OEM Wi-Fi High Temperature Sensor uses an RTD to accurately measure temperatures from  $-50^{\circ}\text{C}$  to  $+370^{\circ}\text{C}$  ( $-58^{\circ}\text{F}$  to  $700^{\circ}\text{F}$ ). Perfect for high temperature critical applications such as ovens, heaters, furnaces and boilers. An integrated 802.11 b/g radio allows the sensor to work with any existing Wi-Fi network. OEM Wi-Fi sensors can be easily programmed with your Wi-Fi network's WEP or WPA(2) security via the free Wi-Fi Setup Utility (PC application) and a USB programming cable (available in the [Monnit web store](#)). User defined transmission intervals (heartbeats) and sensor threshold settings ensure that sensor data is received when needed, based on the application.

#### Features

- Accurate to  $\pm 0.3^{\circ}\text{C}$  @  $0^{\circ}\text{C}$ .
- RTD temperature range:  $-50^{\circ}\text{C}$  to  $+370^{\circ}\text{C}$ . ( $-58^{\circ}\text{F}$  to  $700^{\circ}\text{F}$ ).
- Good for high temperature applications.
- Logs data if Wi-Fi network is disrupted.
- Free iMonnit basic online wireless sensor monitoring and notification system to configure sensors, view data and set alerts via SMS text and email.

(iMonnit online software is available as an OEM private / white label platform.)

#### Principle of Operation

The OEM Wi-Fi High Temperature Sensor outputs the ambient temperature in degrees Celsius or Fahrenheit. It is programmed to sleep for a user-given time interval (heartbeat) and then wakeup, power up the RTD sensor and wait for it to stabilize then mathematically compute the temperature and transmit the data to the gateway.

#### OEM Wi-Fi Sensor Electronics Specifications

- Power: 2 replaceable 1.5V "AA" batteries (included)
- Communication: 802.11 b/g  
(2.412 - 2.484 GHz)
- Wi-Fi Security: Open, WEP, WPA, WPA2
- Dimensions: 3.02" x 2.1" x 1.27"
- Transmission Range: Up to 250 ft. \*
- Battery Life: Up to 5 years. \*\*

\* Actual range may vary depending on environment.  
\*\* Battery life is affected by sensor type, Wi-Fi security type, distance from Wi-Fi router, reporting frequency and other variables.

Height: 1.270 in (32.258 mm)

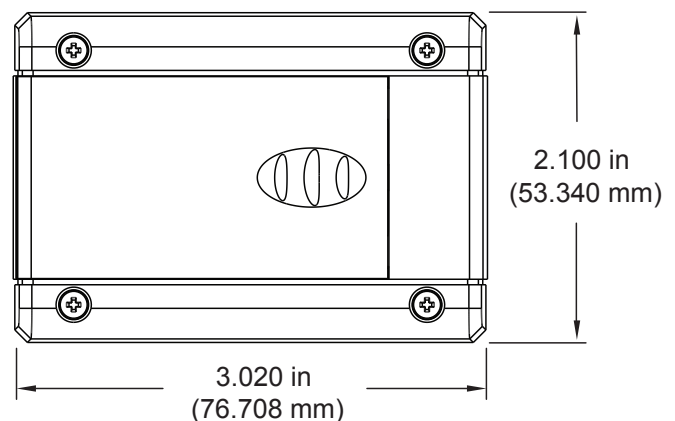

#### Applications

- Heaters & Boilers
- Ovens & Cooking Devices
- Environmental Monitoring
- Smart Machines & Smart Structures
- HVAC Operation & Testing

## Technical Specifications

Networking Standards	IEEE 802.11 b/g
Frequency Band	2.412 - 2.484 GHz
Wi-Fi Security Standards	Open, WEP, WPA, WPA2
Wi-Fi Security Programming	Via PC software using USB cable. (Can be changed through iMonnit online software.)
Network Settings	Auto DHCP/DNS or Static
Data Logging	Standard - On Wi-Fi disruption, unit will log the first 50 readings and transmit when Wi-Fi connection is re-established. Premiere - Unit can record up to 50,000 readings and transmit when Wi-Fi is available.
Power consumption	4uA sleep, 35mA active RX, 180mA TX (at +12dBm)
Battery Life	Up to 5 years depending on sensor type, Wi-Fi security, distance from Wi-Fi router, reporting frequency and other variables. (Testing surpassed 90,000 transmissions until battery depletion.)
Wi-Fi Data Rate	Auto configures to best rate for maximum range.
Wireless Range	Up to 250 ft. device range (typical to standard Wi-Fi devices).
Electronics Operating Temperature	Using Alkaline Batteries: -18°C to +55°C (0°F to +130°F) Using Lithium Batteries: -40°C to +85°C (-40°F to +185°F)
LED Light	Status / activity
Certifications	 FCC ID: T9J-RN171. IC: RSS-210 low-power communication device. CE ID: 0681.

## RTD Technical Specifications

RTD Temperature Range (RTD and Cable Only)	-50°C to +370°C (-58°F to 700°F)
Accuracy @ 25°C	+/- 0.5°C (0.9°F)
Dissipation Constant	2mW/°C
Thermal Time Constant	15 sec max.

\* Hardware can not withstand negative voltage. Please take care when connecting a power device.

\*\* At temperatures above 100°C, it is possible for the board circuitry to lose programmed memory.

For more product information, to get a quote, or to place an order, please contact our sales department at 801-561-5555. Visit us on the web at [www.oemsensors.com](http://www.oemsensors.com).

OEMSensors.com | 7304 South Cottonwood, Suite #204 | Midvale, Utah 84047 | 801-561-5555 | [www.oemsensors.com](http://www.oemsensors.com)